

Dirty Air Pitot Probe with Fast-Lock Dustless Connector



Velocity testing in a coal piping system

The Dirty Air Pitot (DAP) probe is utilized to measure air velocity, pressure, and temperature within a flow stream that is heavily laden with particulate.

Compared to other pressure-type velocity probes, the design of the DAP reduces the potential for pluggage of the pressure lines, a situation that will yield erroneous results. The DAP probe is generally used to measure the air or gas flow rate in pneumatic conveying systems. These may include piping or duct systems that transport cement, pulverized coal, lime, or food products.

The DAP probe measures the velocity of the transport flow and thus can provide the data necessary to balance flows and avoid dust dropout due to low velocities. Determining the air velocity is necessary if isokinetic particulate flow sampling is desired (i.e., ISO 9931, ASME PTC 4.2, etc.).

Compared to the standard dirty air pitot test system, the dirty air pitot test system with Fast-Lock Dustless Connector offers increased useability and efficiency. Integrated into the Fast-Lock Dustless Connector is a traverse rod that allows the operator to smoothly and easily transition from one sample point to another. The probe includes an integrated thermocouple for temperature measurement.

ASE calibrates every DAP in our NIST-traceable wind tunnel. This is very important for accurate results because DAP probes do not have a calibration coefficient of 1. The calibration also includes static pressure since this value, with the temperature, is used to determine the flow density, which is required to calculate mass flow.

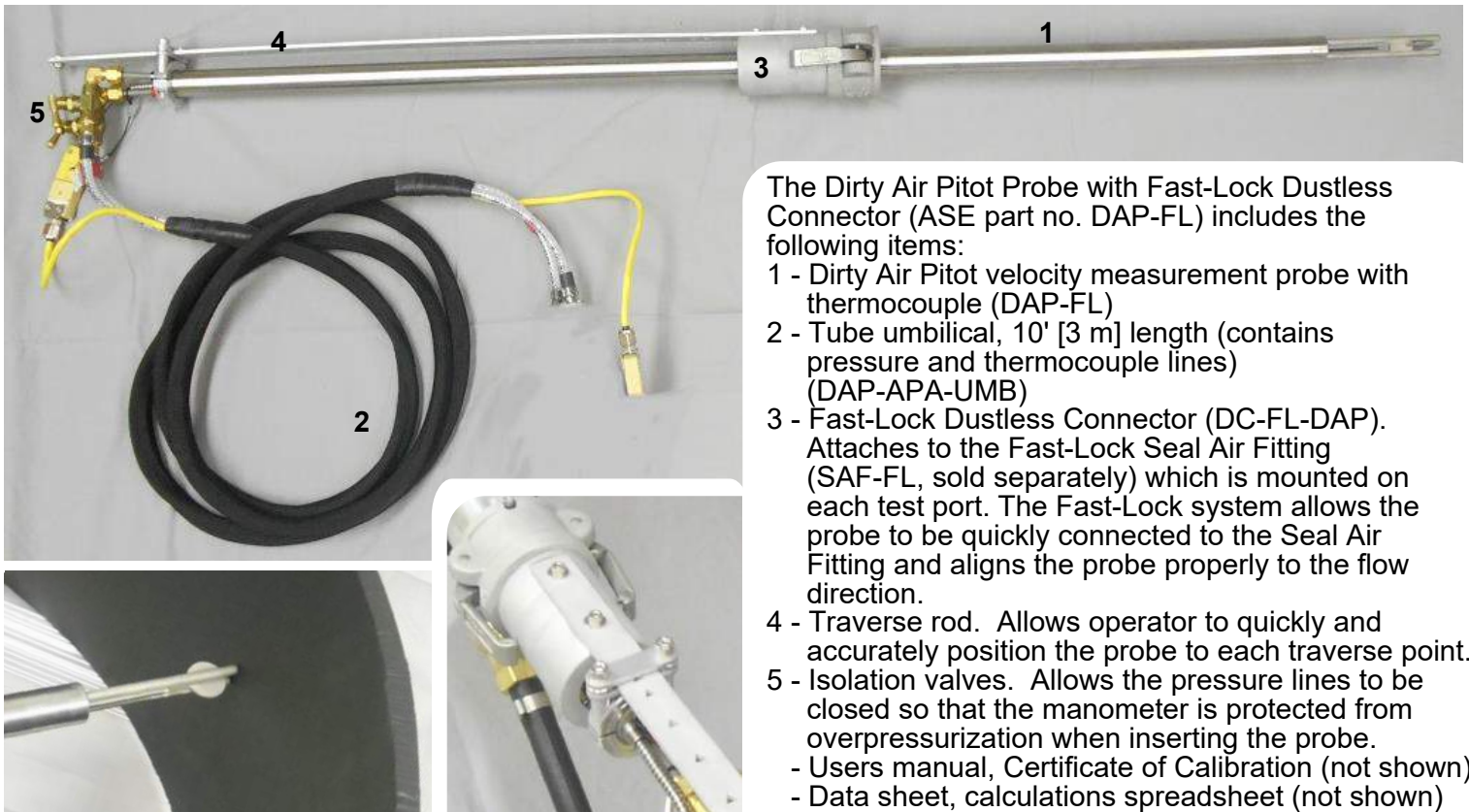

The Dirty Air Pitot Probe with Fast-Lock Dustless Connector (ASE part no. DAP-FL) includes the following items:

- 1 - Dirty Air Pitot velocity measurement probe with thermocouple (DAP-FL)
 - 2 - Tube umbilical, 10' [3 m] length (contains pressure and thermocouple lines) (DAP-APA-UMB)
 - 3 - Fast-Lock Dustless Connector (DC-FL-DAP). Attaches to the Fast-Lock Seal Air Fitting (SAF-FL, sold separately) which is mounted on each test port. The Fast-Lock system allows the probe to be quickly connected to the Seal Air Fitting and aligns the probe properly to the flow direction.
 - 4 - Traverse rod. Allows operator to quickly and accurately position the probe to each traverse point.
 - 5 - Isolation valves. Allows the pressure lines to be closed so that the manometer is protected from overpressurization when inserting the probe.
- Users manual, Certificate of Calibration (not shown)
 - Data sheet, calculations spreadsheet (not shown)

Dirty Air Pitot Probe with Fast-Lock Dustless Connector Details and Specifications

The dirty air pitot probe with Fast-Lock Dustless Connector from Airflow Sciences Equipment, LLC (ASE) can be manufactured to fit a variety of testing needs. Construction is 304 stainless steel. Example dimensions are shown below, though probes are customized per client specifications. Photos provide details of component construction.

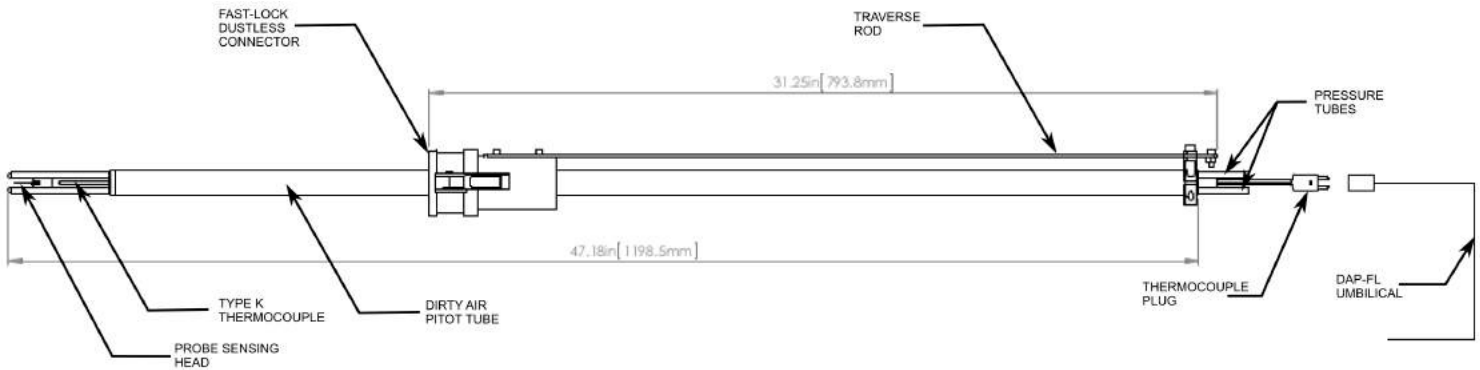

Fast-Lock Seal Air Fitting

The Fast-Lock Seal Air Fitting allows the operator to safely insert the DAP and ISO probes while providing the proper alignment and orientation for an accurate test. The photos and drawing below depict the Fast-Lock Seal Air Fitting (SAF-FL). The SAF-FL uses plant compressed air to provide a curtain of air that seals against the high pressure in the pipe. The SAF-FL thus keeps the air and particulate from escaping out of the pipe when inserting the probe. ASE uses a ball valve for additional safety of test personnel.



Fast-Lock Seal Air Fitting (mounts on each pipe, sold separately) is a snap to close

